

Foundation Gas/Electric Rooftop

Unit Overview - GBC036A3EMB**000000000000000000000000

Application	Unit Size	Supply Fan		External Dimensions (in.)			Operating Weight		EER	IEER/SEER	Elevation
		Airflow	External Static Pressure	Height	Width	Length	Minimum	Maximum			
Gas/Electric	3 Ton	1200 cfm	0.500 in H2O	3.55 ft	3.99 ft	6.40 ft	524.0 lb	723.0 lb	12.0 EER	14.00	

Unit Features

Unit Electrical

Voltage/phase/hertz	208-230/60/3
MCA	20.00 A
MOP	25.00 A



Controls

Unit Controls Electro-mechanical

Cooling Section

		Capacity	
Entering Dry Bulb	80.00 F	Gross Total	37.11 MBh
Entering Wet Bulb	67.00 F	Gross Sensible	28.13 MBh
Ambient Temp	95.00 F	Net Total	35.12 MBh
Leaving Coil Dry Bulb	57.83 F	Net Sensible	26.15 MBh
Leaving Coil Wet Bulb	56.99 F	Refrig Charge-circuit 1	3.5 lb
Leaving Unit Dry Bulb	59.93 F		
Leaving Unit Wet Bulb	57.79 F		

Heating Section

Output Heating Capacity	80.00 MBh
Output Heating Capacity with Fan	80.00 MBh
Heating EAT	70.00 F
Heating LAT	131.44 F
Heating Temp Rise	61.44 F

Fan Section

Indoor Fan Data		Outdoor Fan Data	
Type	FC Centrifugal	Type	Propeller
Drive Type	Belt	Fan Quantity	1
Indoor Fan Performance		Outdoor Fan Performance	
Airflow	1200 cfm	Condenser Fan FLA	1.40 A
Design ESP	0.500 in H2O	Exhaust Fan Data	
Component SP	0.000 in H2O	Type	FC Centrifugal
Total SP	0.500 in H2O	Drive Type	Direct
Indoor Motor Operating Power	0.38 bhp	Exhaust Fan Performance	
Indoor Motor Power	0.28 kW	Exhaust Fan FLA	5.00 A
Indoor RPM	779 rpm		

Compressor Section

Circuit 1 RLA	10.40 A
Circuit 2 RLA	0.00 A

These cut sheets are for reference only. Stock model numbers may differ. Contact your salesperson for job specific submittals for engineer approval.

NOTES:

1. THRU -THE -BASE ELECTRICAL IS NOT STANDARD ON ALL UNITS.
2. VERIFY WEIGHT, CONNECTIONS, AND ALL DIMENSIONS WITH INSTALLER DOCUMENTS BEFORE INSTALLATION
3. DISCONNECT SWITCH IS NOT STANDARD ON ALL UNITS.

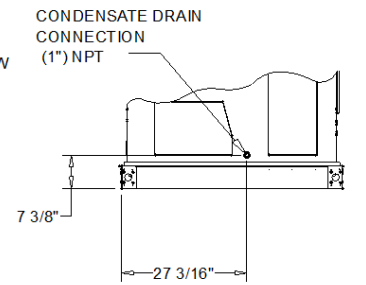
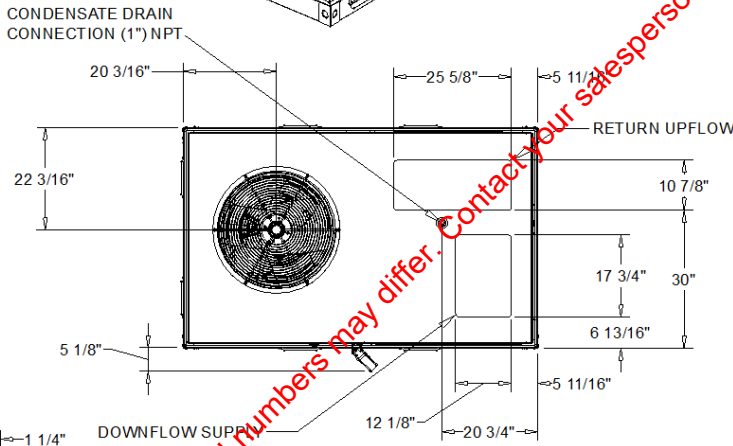
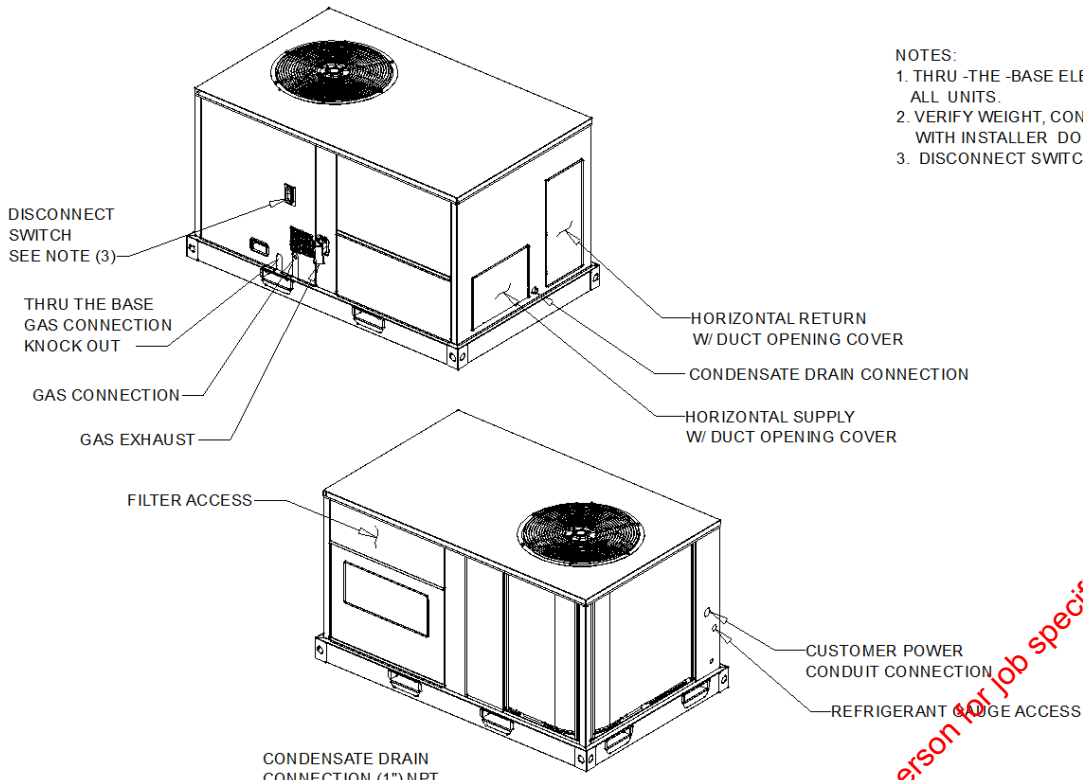

CONDENSATE DRAIN
DIMENSION DRAWING

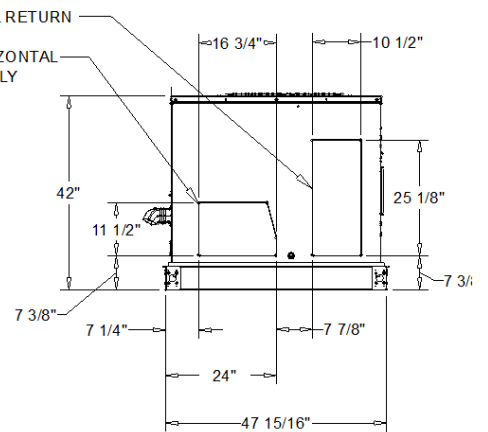
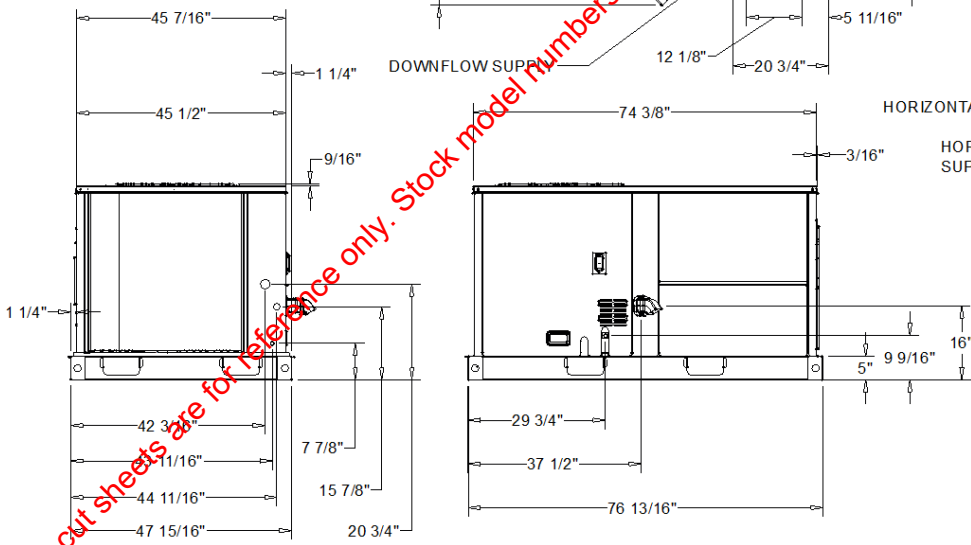

3 - 5 PACKAGED COOLING

DIMENSION DRAWING

These cut sheets are for reference only. Stock model numbers may differ. Contact your salesperson for job specific submittals for engineer approval.

ELECTRICAL / GENERAL DATA

GENERAL (2)(4)(6)(7)(10) Model: GBC036 Oversized Motor Unit Operating Voltage: - Unit Primary Voltage: 208 MCA: Unit Secondary Voltage: 230 MFS: Unit Hertz: 60 MCB: Unit Phase: 3 EER: 12 / 14 IEER One Speed Fan: - IEER Multi Speed Fan: - Standard Motor Field Installed Oversized Motor MCA: 19.5 MCA: MFS: 25.0 MFS: MCB: 25.0 MCB:		HEATING PERFORMANCE HEATING - GENERAL DATA Heating Model: Medium Heating Input (BTU): 100000 / 80000 Heating Output (BTU): 80000/64000 No. Burners: 3 No. Stages: 2 Gas Inlet Pressure Natural Gas (Min/Max): 4.5 / 14.0 in. wc LP (Min/Max): 11.0 / 14.0 in. wc Gas Pipe Connection Size: 1/2"	
INDOOR MOTOR Standard Motor Oversized Motor Field Installed Oversized Motor Number: 1 Number: Number: Horsepower: 1.0 Horsepower: Horsepower: Motor Speed (RPM): - Motor Speed (RPM): Motor Speed (RPM): Phase: 3 Phase Phase Full Load Amps: 5.0 Full Load Amps: Full Load Amps: Locked Rotor Amps: 24.5 Locked Rotor Amps: Locked Rotor Amps:			
COMPRESSOR Circuit 1/2 Number: 1 Horsepower: 4.10 Phase: 3 Rated Load Amps: 10.4/11.6 Locked Rotor Amps: 73.0		OUTDOOR MOTOR Number: Horsepower: 9.33 Motor Speed (RPM): - Phase: 3 Full Load Amps: 1.4 Locked Rotor Amps: 4.6	
POWER EXHAUST ACCESSORY (3) (Field Installed Power Exhaust) Phase: Horsepower: Motor Speed (RPM): Full Load Amps: Locked Rotor Amps:	FILTERS Type: Throwaway Furnished: Yes Number: 4 Recommended: 16"x16"x2"		REFRIGERANT (2) Type: R-410A Factory Charge: Circuit #1 3.5 lb Circuit #2

NOTES:

1. Maximum (HACR) Circuit Breaker sizing is for installations in the United States only.
2. Refrigerant charge is an approximate value. For a more precise value, see unit nameplate and service instructions.
3. Value does not include Power Exhaust Accessory.
4. Value does not include Heater.
5. Value include Standard Motor.
6. Value include Oversized Motor
7. EER is rated at AHRI conditions and in accordance with DOE test procedures.
8. For Compressor Motors and Condenser Fan Motors: Amp draw for each motor; multiply value by number of motors to determine total amps.
9. HP for each compressor.
10. Integrated Energy Efficiency Ratio (IEER) is rated in accordance with AHRI standard 210/240 or 360.
11. Full Load Amps (FLA) are the combined amps for outdoor motors.

These cut sheets are for reference only. Stock model numbers may differ. Contact your salesperson for job specific submittals for engineer approval.

Base Unit and Corner Weights only

Base unit weights		Corner Weights				Center of Gravity	
SHIPPING	NET	(A)	(B)	(C)	(D)	E	F
574.0 lb	524.0 lb	95.0 lb	111.0 lb	172.0 lb	146.0 lb	42"	29"

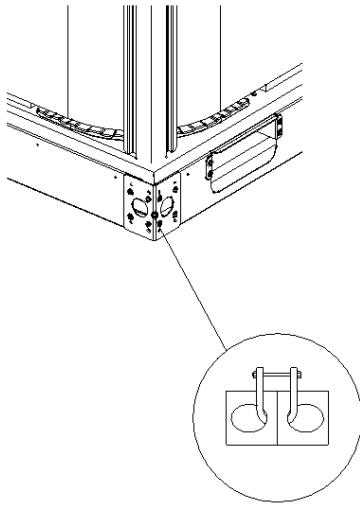

PACKAGED COOLING PLAN VIEW

RIGGING DRAWING

1. All weights are approximate.
2. The actual weight are listed on the unit nameplate.
3. Refer to unit nameplate and installation guide for weights before scheduling transportation and installation of unit.
4. The weight shown represents the typical unit operating weight for the configuration selected. Estimated at +/- 10 % of the nameplate weight.
5. Verify weight, connection, and all dimension with installer documents before installation.
6. Corner weights are given for information only.
7. Net/Shipping weight of optional accessories should be added to unit weight when ordering factory or field installed accessories.

Installed Options Net Weight Data

Accessory	Weight
Economizer, Manual and Motorized Outside Air Damper	.
Barometric Relief	.
Power Exhaust	.
Roof Curb	.
Oversized Motor	.
Disconnect	.
Hail Guard	.
Through the Base	.
Through the Gas	.
	.
	.

1. Weights for options are approximate.
2. Weights for options that are not list refer to Installation guide.

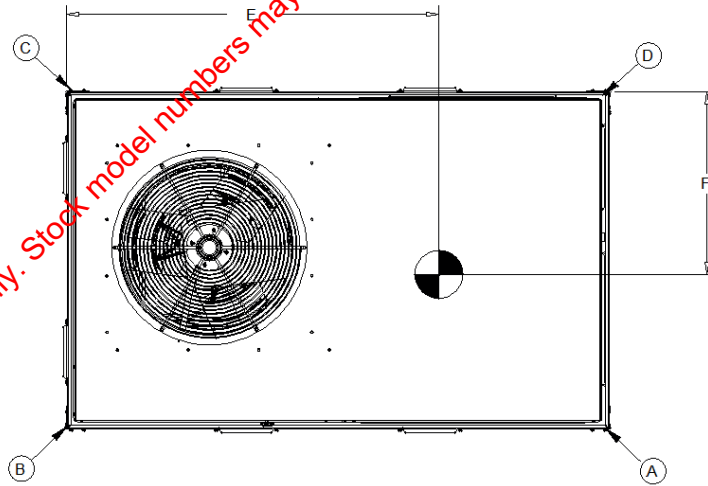

PACKAGED GAS/ELECTRIC PLAN VIEW

CENTER OF GRAVITY DRAWING

These cut sheets are for reference only. Stock model numbers may differ. Contact your salesperson for job specific submittals for engineer approval.

NOTES:
1. THRU-THE-BASE ELECTRICAL IS NOT STANDARD ON ALL UNITS.

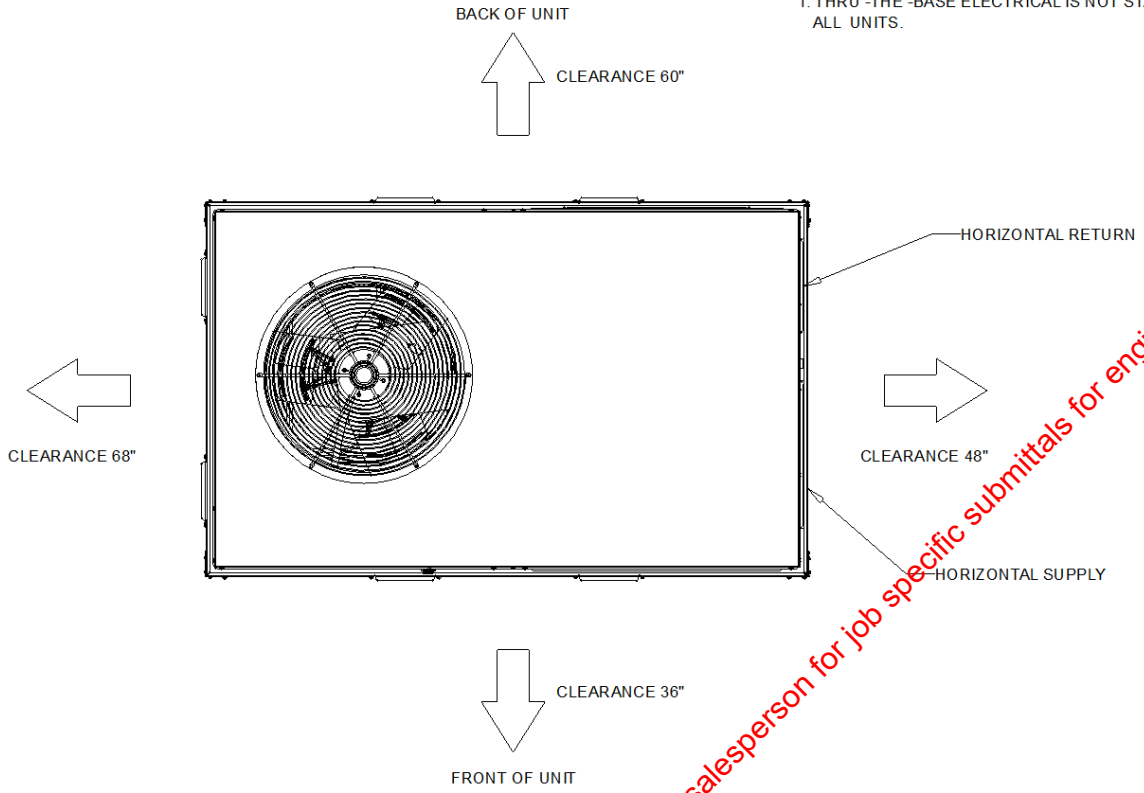

PACKAGED GAS / ELECTRIC PLAN VIEW
CLEARANCE DRAWING

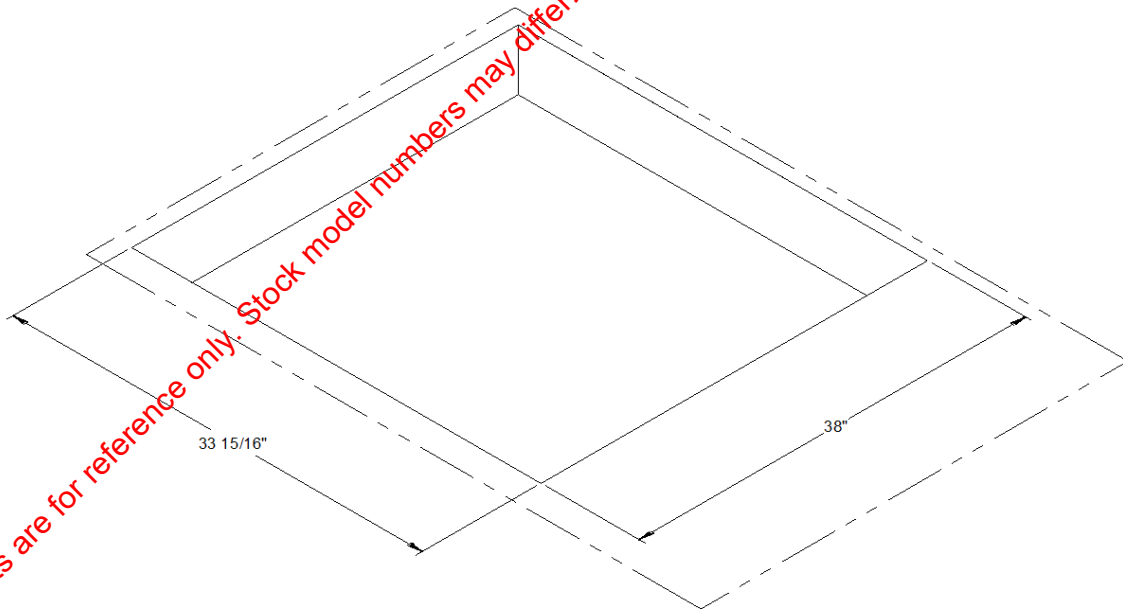

PACKAGED GAS / ELECTRIC PLAN VIEW
DOWNFLOW CLEARANCE DRAWING

These cut sheets are for reference only. Stock model numbers may differ. Contact your salesperson for job specific submittals for engineer approval.

3 thru 5 Ton General

The units shall be convertible from downflow or horizontal airflow. The operating range shall be between 125.0 F and 40.0 F in cooling as standard from the factory for all units. Cooling performance shall be rated in accordance with ARI testing procedures. All units shall be factory assembled, internally wired, fully charged with R-410A, and 100 percent run tested to check cooling operation, fan and blower rotation and control sequence, before leaving the factory. Wiring internal to the unit shall be colored and numbered for simplified identification. Units shall be UL listed and labeled, classified in accordance to UL 1995/C 22.2, 236-05 5rd Edition.

3 thru 5 Ton Casing

Unit casing shall be constructed of zinc coated, heavy gauge, galvanized steel. Exterior surfaces shall be cleaned, phosphatized, and finished with a weather-resistant baked enamel finish. Unit's surface shall be tested 672 hours in a salt spray test in compliance with ASTM B117. Cabinet construction shall allow for all maintenance on one side of the unit. In order to ensure a water and air tight seal, service panels shall have lifting handles and no more than four screws to remove. All exposed vertical panels and top covers in the indoor air section shall be insulated with a 1/2", 1.0 lb density foil-faced, fire-resistant, permanent, dorless, glass fiber material. The base of the downflow unit shall be insulated with 1/2", 1.0 lb density foil-faced, closed-cell material. The downflow unit's base pan shall have no penetrations within the perimeter of the curb other than the raised 1 1/8" high supply/return openings to provide an added water integrity precaution, if the condensate drain backs up. The base of the unit shall have provisions for forklift and crane lifting.

3 thru 5 Ton Compressors

All units shall have direct-drive, hermetic, scroll type compressors with centrifugal type oil pumps. Motor shall be suction gas-cooled and shall have a voltage utilization range of plus or minus 10 percent of nameplate voltage. Internal overloads shall be provided with the scroll compressors. All models shall have phase monitors and low and high pressure control as standard.

3 thru 5 Ton Controls

Unit shall be completely factory wired with necessary controls and contactor pressure lugs or terminal block for power wiring. Unit shall provide an external location for mounting a fused disconnect device.

3 thru 5 Ton Discharge Line Thermostat

A bi-metal element discharge line thermostat is installed as a standard option on the discharge line of each system. This standard option provides extra protection to the compressors against high discharge temperatures in case of loss of charge, extremely high ambient and other conditions which could drive the discharge temperature higher. Discharge line thermostat is wired in series with high pressure control. When the discharge temperature rises above the protection limit, the bi-metal disc in the thermostat switches to the off position, opening the 24 Vac circuit. When the temperature on the discharge line cools down, the bi-metal disc closes the contactor circuit, providing power to the compressor.

3 thru 5 Ton Evaporator and Condenser Coils

Microchannel coils will be burst tested by the manufacturer. Microchannel condenser coils shall be standard on all units. Coils shall be leak tested to ensure the pressure integrity. The evaporator coil and condenser coil shall be leak tested to 225 psig and pressure tested to 450 psig. Sloped condensate drain pans are standard.

3 thru 5 Ton Filters

Two inch standard filters shall be factory supplied on all units.

3 thru 5 Ton Gas Heating Section

The heating section shall have a tubular heat exchanger design. An induced draft combustion blower shall be used to pull the combustion products through the firing tubes. The heater shall use a direct spark ignition (DSI) system. On initial call for heat, the combustion blower shall purge the heat exchanger for 20 seconds before ignition. After three unsuccessful ignition attempts, the entire heating system shall be locked out until manually reset at the thermostat. Units shall be suitable for use with natural gas or propane (field-installed kit) and also comply with the California requirement for low NOx emissions (Gas Heat Only).

3 thru 5 Ton High Pressure Control

All units include High Pressure Cutout as standard.

3 thru 5 Ton Indoor Fan

Units above shall have belt driven, FC centrifugal fans with adjustable motor sheaves. All motors shall be thermally protected. Oversized motors shall be available for high static application. All indoor fan motors meet the U.S. Energy Policy Act of 1992 (EPACT).

3 thru 5 Ton Low Pressure Control

All units include low pressure cutout as standard.

3 thru 5 Ton Outdoor Fans

The outdoor fan shall be direct-drive, statically and dynamically balanced, draw-through in the vertical discharge position. The fan motor(s) shall be permanently lubricated and shall have built in thermal overload protection.

3 thru 5 Ton Phase Monitor

The Phase Monitor is a three-phase line monitor module that protects against phase loss, phase reversal and phase unbalance. It is intended to protect compressors from reverse rotation. It has an operating input voltage range of 190-600 Vac, and LED indicators for ON and FAULT. There are no field adjustments and the module will automatically reset from a fault condition.

3 thru 5 Ton Refrigerant Circuits

Each refrigerant circuit shall have independent thermal expansion valve, service pressure ports, and refrigerant line filter driers factory installed as standard. An area shall be provided for replacement suction line driers.

3 thru 5 Ton Unit Top

The top cover shall be double hemmed and gasket sealed to prevent water leakage.

These cut sheets are for reference only. Stock model numbers may differ. Contact your salesperson for job specific submittals for engineer approval.